



Do ICT Development and labor force foster Economic Growth in Indonesia?

Siti Mudrikah¹, Muhammad Fathrul Quddus²

¹Airlangga University, ²Airlangga University
email siti.mudrikah-2020@feb.unair.ac.id

Abstract

Purpose: This paper aims to determine the ICT Development Index and other supporting variables affecting Indonesia's economic growth.

Methods: This study uses secondary data from 1996-2019. Using economic growth variables as endogenous variables, and labor force, gross fixed capital formation (GFCF), cellular phones per 100 people, fixed telephones per 100 people, and internet users as exogenous variables. The data analysis technique used OLS multiple linear regression with eviews 9 application.

Finding: The neoclassical theory developed by Solow (1957) a name "Growth Accounting" that economic growth formed from the factors of production and technology. This finding only the variable Mobile cellular per 100 people does not affect economic growth in Indonesia, and other variables are significant.

Novelty: This study uses an innovation variable, namely the ICT Development Index, to complement the variables of production factors (labor and GFCF). This study focuses on Indonesia because it is about Indonesia's potential use of technology and information, among indications of the use of telephone and internet users in Indonesia.

Implications: Further research can apply other ICT Development variables such as ICT exports or use the other countries.

Key word :

*GDP, Gross Fix
Capital Formation,
Internet User,
Labor Force*

INTRODUCTION

The country can be said to be prosperous and prosperous by looking at the success of economic development, while one of the indicators is economic growth. Economic growth is an important variable in a country. According to Budiman 1996 (Suradi, 2012), the success of economic development is with high economic growth that uses the level of expansion or increase in Gross Domestic Product as a benchmark for economic growth. Meanwhile, Munir 2008 revealed that economic growth is seen in terms of increasing output, goods, and services to meet the needs of life, which are increasing from time to time; economic growth is also functioned to improve the standard of living and quality of life of the community (Suradi, 2012).

Solow's theory clarifies how saving, population growth, and technological progress affect economic output and result and its development over the long run. Solow's new theory, the New Growth Theory, links economic growth and technology. The theory mentions indicators of worker efficiency and technological developments. Meanwhile, according to Romer, humans, and technology are important sectors in economic growth. The available labor, human capital, and production-resistant goods produce Murtiadi (2019). Todaro explained three main components that can affect economic growth: a). Accumulation of capital goods, including all types of investment (both physical equipment and human capital. b). The increase in population will increase the number of the workforce. c). Technological Progress (Yogaswara, 2015).

According to N. Gregory Mankiw in Maulidiyah (2018), labor and capital are factors for economic growth. Perception Todaro 2000 in Munthe (2014) that population growth and labor force (AK) will traditionally be determining factors that trigger economic growth. When the number of workers increases, it will also be in line with an increase in production level. This is different from the research conducted by (Samoilenko & Osei-Bryson, 2008) that there is no relationship between investment and labor force on GDP. In contrast to the findings of (Insani & Indra, 2015), which states that the labor force significantly affect on economic growth in the OIC country from 2003-2019.

Gross Fixed Capital Formation (GFCF), better known as Gross Fixed Capital Formation, is an expenditure for capital product that have a life expectancy of over one yaear and are not consumption goods Bakkara, (2017). Andinata et al., (2018) GFCF has a significant effect and has a positive coefficient on Gross Domestic Product (GDP) in ASEAN member countries. When the amount of GFCF of a country increases, the amount of GDP in ASEAN member countries will also increase. Research conducted by (Ipa Jamiah Arfa, 2015) also says that the effect of gross fixed capital formation (GFCF) has a positive and significant influence on economic growth in Indonesia. Gross Fixed Formation or gross fixed capital formation has a positive and significant impact on ASEAN economic growth.

Ahmad (2021) said a relationship between pro-cycle technology development on GDP, exports, imports, labor force, and gross fixed capital formation (GFCF) during a recession. This variable had a significant effect on the patent variable. The GDP innovation model also proposes that firms are more willing to introduce innovations when the market grows (boom period) or demand increases.

One indication of the success of economic growth in a country is the level of technological development used in that country. Technology can change production to be more efficient. For example, the UK, which can produce relatively large output with relatively few resources, became the first industrial economy globally.

The availability of adequate infrastructure is a prerequisite that must be available in an economic system so that economic and social activities can run well. One of the infrastructures that allegedly role an important role in supporting economic growth at the company, regional, national, and even international levels is Information and Communication Technology (ICT) or Information and Communication Technology (ICT) Murtiadi, (2019). According to Weigel and Waldburger (2004): "ICT refers to technology designed to access, process and transmit information. ICT includes all technologies – from widely used traditional devices such as radio, telephone or TV, to more sophisticated devices such as computers and the internet". Therefore, information technology and communication technology are two things that have mutual attachment Murtiadi, (2019). The findings from Rath & Hermawan (2019) say that ICT development significantly affects economic growth.

Indonesia is a country with the biggest populance in Southeast Asia is as yet a non-industrial nation . Indonesia is still lagging in the ICT sector compared to other countries like Singapore and Malaysia (Rath & Hermawan, 2019). It can be said that Indonesia is a densely populated country, so there is potential for ICT development that will impact people's per capita income. This study aims to determine the factors of economic growth in Indonesia by involving innovation factors, namely technology, and several other factors, namely labor force and Gross fixed capital formation. Based on reports from BPS in most recent five years, the utilitization of Information and Communication Technology (ICT) by households in Indonesia shows very good development. The percentage of the population using cell phones also continued to increase, until in 2019, it reached 63.53 percent (BPS, 2019)

LITERATURE REVIEW

Economic Growth

According to Solow, the theory of economic growth explains its components, namely saving, population growth, and technological progress, that will affect economic output. This theory is based on the production function. Then the Solow growth model provides a theoretical framework for understanding the sources of economic growth and the consequences of environmental changes and economic policies for long-term growth. This growth accounting theory is also an extension of the Solow growth model where the results obtained from this calculation are values that measure how much the contribution of each input factor of production to the formation of economic growth Barro and Sala i-Martin, 2004 in (Murtiadi, 2019)

This study refers to the neoclassical theory developed by Solow (1957) "Growth Accounting" Samoilenko & Osei-Bryson, 2008 with the following equation:

$$Y = f(A, K, L)$$

where :

Y : GDP

A: ICT Development

K: Gross Fixed Capital Formation L: Labor Force

Where Y is Economic Growth, A is technology, K is capital, L is labor.

Labor force and economic growth

The labor force (labor force) is the population of working age (15-64) years who are working and not working but are ready to look for work (Menajang, n.d.). Concerning economic growth, when the number of productive workers is high or increases, it will certainly increase the level of production and will ultimately affect people's income. (Munthe, 2014) in his research, the labor force had a significant effect on economic growth. (Ahmad, 2021), Export, labor force, and import significantly affect patents (residential and non-residential).

H1: Labor force has a positive effect on economic growth

Gross Fixed Capital Formation and Economic Growth

Gross Fixed Capital Formation is expenditure for capital goods with a service life of more than one year and is not consumer goods. Virtyani et al., 2021, Gross Fixed Capital Formation either partially or jointly has a significant effect on per capita national income in Indonesia. In the study, it was stated that one of the factors was the ease of doing business. An increase in total production will affect the amount of company income, which will continuously positively affect the country's national income.

H2: GFCF has a positive effect on Economic Growth

ICT Development and Economic growth

Rath & Hermawan (2019) presents ICT Development indicators in Indonesia, namely Fixed-telephone subscriptions per 100 inhabitants, Mobile-Cellular subscriptions per

100 inhabitants, ICT Index, Fixed Broadband subscriptions per 100 inhabitants, internet users (100%), Household with a computer (100%). In this study, only three indicators of ICT Development were used.

Mobile cellular subscription per 100 people and Economic Growth

Mobile Cellular Subscription has a positive and significant effect on FDI Koyuncu & Unver, (2016). Prasetyo (2016) said that the communication infrastructure variable, measured using a mobile cellular subscription per 100 people and fixed telephone, says that these two factors affect economic growth with the supposition that the impact of telecommunications infrastructure development just show through the product. The development of telecommunications infrastructure is considered as the impact of increasing economic growth. Katz & Koutroumpis, (2014) mobile phones fundamentally affect impact on growth.

H3: Mobile cellular subscription per 100 people has a positive effect on Economic Growth

Fix telephone subscription per 100 people and Economic Growth

Koyuncu & Unver, (2016) Fixed Telephone Subscription has a positive and significant effect on FDI, assuming that the ease and high impact of using the technology will ultimately improve the economy. Sridhar & Sridhar, (2008) The effect

of fixed phones and cell phones are positive and significant on economic growth in developing countries.

Romer (1987) model of economic growth using telecommunications infrastructure as estimated by telephone liners per 100 people has a significant positive inhibition on long-run economic growth.

H4: Fix telephone subscription per 100 people has a positive effect on Economic Growth

Internet Users and Economic Growth

Donou-Adonsou et al., (2016) internet users can influence economic growth in Sub- Saharan Africa. This study states that an increase of one percent in interner users and mobile phones can increase per capita income by 0, 12- and 0.03 percent, respectively. Myovella et al., (2020), in their research on ICT variables, including internet users and mobile subscriptions, show a positive impact on economic growth.

H5: Internet users have a positive effect on Economic Growth

THEORETICAL FRAMEWORK AND HYPOTHESES

Gambar 1
Copceptual Framework

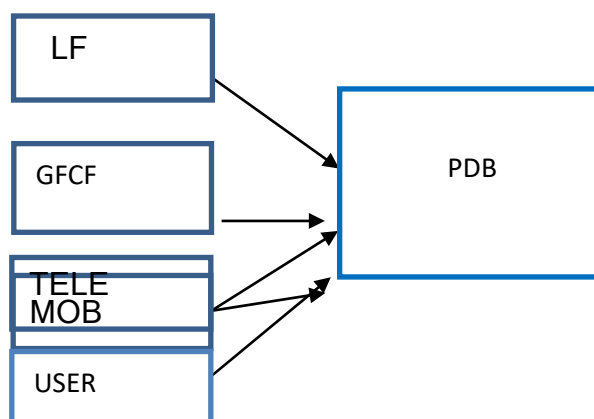

RESEARCH METHOD

The data analysis method used is multiple linear regression analysis (Multiple Regression Model) using the classical assumption test (Ordinary Least Square). This Linear Regression method is used to determine the effect of the ICT index, Labor force, and Gross Fix Capital Formation on GDP. The data source is time series data from 1996-2019 from secondary sources. Secondary data researchers access from <https://www.theglobaleconomy.com/Indonesia/> and the world bank website, which can be accessed at <https://data.worldbank.org/>.

The econometric model of the multiple linear regression equation is as follows:
$$Y_t = \beta_0 + \beta_1 X_1 + \beta_2 X_2 + \beta_3 X_3 + \beta_4 X_4 + \beta_5 X_5 + e$$

Description:

$Y = \text{GDP}$

β_1 = the magnitude of the effect of LF

β_2 = magnitude of effect of GFCF

β_3 = the magnitude of the effect of MOB

β_4 = the magnitude of the effect of TELE

β_5 = the magnitude of the effect of USER

β_0 = Constanta

Data analysis technique

This study uses multiple regression analysis of time series data with an Ordinary Least Square (OLS) approach and uses the EViews 9 application program as a research tool.

the steps to be taken for time series data regression analysis in this study are as follows:

1. Test the hypothesis
2. Classical Assumption Test

RESULT AND DISCUSSION

Regression Result

Table 1 : Hypothesis test

<u>Variabel</u>	<u>Koefisien</u>	<u>Std Error</u>	<u>t-Statistik</u>	<u>Prob</u>
C	-5.90E+11	2122.237	4.126457	0.0197
LF	8757.317	1.87E+09	4.053575	0.0006
GFCF	7.59E+09	130.1753	1.468356	0.0007
MOB	191.1436	716.1287	-2.468991	0.1593
TELE	-1768.115	1.43E+09	2.322273	0.0238
USER	3.33E+09	2.30E+11	-2.560366	0.0321
Adjusted R Square	0.995204			
Prob (F-statistik)	0.000000			

The regression used in this study, the following equation is written:

$$Y_t = -5.90E+11 + 8757.317X_1 + 7.59E+09X_2 + 191.1436X_3 + (-1768.115)X_4 + 3.33E+09X_5$$

The constant value of -5.90E+11 indicates that if LF, GFCF, MOB, TELE, and USER, it indicates that these variables can increase GDP by -5.90E+11.

The coefficient value of the LF variable is 8757,317, which means that if the LF increases by 1%, it will increase GDP by 8757,317, assuming other variables are considered constant and constant. The coefficient value of the GFCF variable is 7.59E, which means that if the GFCF increases by 1%, it will increase GDP by 7.59E assumption other variables are considered constant and constant. The coefficient value of the MOB variable is 191.1436, which means that if the MOB increases by 1%, it will increase GDP by 191.1436 with the assumption that other variables are considered constant and constant. The coefficient value of the TELE variable is - 1768.115, which means that if TELE increases by 1% it will decrease GDP by - 1768.115 assume other variables are considered constant and constant. The coefficient value of the USER variable is 3.33E+09, which means that if USER increases by 1%, it will decrease GDP by 3.33E+09, assuming other variables are considered constant and constant.

Normality Test

The normality test of the data was carried out to determine whether the data obtained were normally distributed or not. The normality test was carried out using a normal probability plot graph approach.

Table 2: Normality test

Jarque-Bera	1.049383
-------------	----------

Probability	0.591738
-------------	----------

Based on the table, it can be seen that the probability or significance value > 0.05 is 0.974. So it can be said that the data in this study are normally distributed.

ROBUSTNESS TEST

This study uses the ICT Development Index indicators, namely MOB and TELE, which have almost the same meaning. TELE is a fixed-line subscription referring to the number of active analog fixed telephone lines, voice-over-IP (VoIP) subscriptions, fixed wireless local loop (WLL) subscriptions, ISDN equivalent voice lines, and fixed public telephones. Meanwhile, MOB is an available cellular telephone service subscription that gives admittance to the PSTN using cellular technology. The marker incorporates the quantity of postpaid memberships and the quantity of dynamic prepaid records (i.e., those used for the last three months). This indicator applies to all mobile subscriptions that offer voice communication. This does not include subscriptions via a data card or USB modem, subscriptions to public cellular data services, private trunked cellular radios, telepoints, paging radios, and <https://data.worldbank.org/telemetry> services.

This research was conducted a robustness test, namely the robustness test, namely by making changes to the data by removing the MOB variable. And the results show that when the MOB variable is removed from the model, the other variables remain the same, which is significant to GDP.

Hypothesis test

Variabel	Coefficient	Std.Error	t-Statistic	Prob
C	-8.85E+11	1.16E+11	-7.603027	0.0000
LF	11384.50	1175.551	9.684393	0.0000
GFCF	9.72E+09	1.22E+09	7.960571	0.0000
TELE	-2366.834	606.3578	-3.903363	0.0010
USER	2.15E+09	1.22E+09	1.757648	0.0949
F-statistic	879.7102			
Prob	0.000000			

DISCUSSION

This study aims to examine the effect of the ICT development index or ICT variable on GDP. The multiple linear regression test results indicate a positive and significant influence between the labor force on GDP so that the statement in H1 states that the labor force on GDP is supported. This shows that the higher the number of the workforce, the more it adds or boosts economic growth. The labor force is greater than the elasticity of investment, understanding that the addition of labor is more effective in increasing economic growth (Munthe, 2014). Similar research by Ahmad (2021), Samoilenko & Osei-Bryson, (2008), (Ariansyah, 2018).

Gross fixed capital formation (GFCF) has a positive and significant effect on GDP. This is evidenced by the acceptance of H2, which states that GFCF has an effect on GDP. Acceptance of this hypothesis confirms that the GFCF is one of the variables triggering the increase in GDP in the economy. Andinata et al. (2018),

Gross fixed capital formation has a significant effect on GDP in ASEAN countries with the assumption that GFCF is an investment in capital goods. It will provide an increase in production capacity by increasing capital goods. This study supports previous empirical studies Ahmad (2021), Andinata et al. (2018).

Contrary as the findings of previous studies such as Koyuncu & Unver. (2016), Prasetyo (2016), Katz & Koutroumpis (2014), Chavula (2013), the results of this study found that Mobile Cellular Subscription (MOB) did not affect GDP. This may be because the distribution and use of MOB in Indonesia are still uneven, and the public still does not fully understand this type of index. This study differs from the BPS report, which says that cellular phone subscribers have increased by 2.3% in 2020 (BPS.go.id).

In contrast to H3, the statement H4 which states that Fix Telephone Subscription per 100 people (TELE) has a positive effect on GDP, is also supported (Supported). In line with previous empirical research, namely Donou-Adonsou et al. (2016), Koyuncu & Unver (2016), Sridhar & Sridhar (2008). Chavula (2013) there is an impact of mobile phones, fixed telephone on the income per capita of 49 people in African countries during the period 1990-2007. This finding says that these two variables positively and significantly affect increasing per capita income (GDP growth). In contrast to the findings, Ariansyah (2018) said that telephones remain insignificant to economic growth.

Based on several significance tests that have been carried out, H5 in this study is accepted or supported, in which the internet user (USER) has a significant effect on GDP. is also in line with the BPS report that internet use has increased from 2016- 2020, which is then shown by the increasing percentage of the population accessing the internet in 2016 at 25.37%, to 53.73% in 2020 ([https:// www.bps.go.id](https://www.bps.go.id)). This is possible due to the impact of Indonesian policies during the COVID-19 pandemic, which forced people to carry out activities online.

Similar research was also conducted by Donou-Adonsou et al., (2016) and Feng (2016). In contrast to Haftu (2019) says that Internet users have no effect on economic growth, for several reasons that internet use does not have an impact on economic activities, technological developments, especially the internet, are something new in SSA so that the impact is not significant, another reason is that there is no availability of local content in the global network, Chavula, (2013) also conducted a similar study.

With the acceptance of four of the five proposed hypotheses, the results of this study add to the literature related to ICT development and several additional variables such as Labor force and Gross Fix Capital Formation, which are associated with economic growth. The results of this study can also be useful for improving the development of existing technology and information where ICT has a major impact on economic activity and lifelines.

CONCLUSION

This study uses the Information and Communication Technology Development Index (IP-TIK), which is a measure that can describe several indications such as the level of improvement data of information and communication technology in a region,

the computerized, and the potential for ICT development (BPS.go.id). Significant effects were found for Labor Force, GFCF, TELE, and USER. Then there is one variable, namely MOB, which does not affect GDP. Technology and communication are important means or keys for economic growth. This research contributes to the literature on the technology and telecommunications index that can assist the government in providing information related to the use of the index to help the government, for example, improve internet access facilities and infrastructure. The availability of technology will affect many things, such as UMKM business, export and import needs, and educational interests. It is hoped that the provision of technology and communication can be penetrated inclusively.

REFERENCES

- Ahmad, M. (2021). Non-linear dynamics of innovation activities over the business cycles: Empirical evidence from OECD economies. *Technology in Society*, 67(August), 101721. <https://doi.org/10.1016/j.techsoc.2021.101721>
- Andinata, C. P., Adenan, M., & Jumiaty, A. (2018). Analisis Pendapatan Nasional di Negara-negara Anggota ASEAN). *Jurnal Ekonomi Ekuilibrium (Jek)*, 2(1), 31–44.
- Ariansyah, K. (2018). Pengaruh Difusi Layanan Telekomunikasi terhadap Pertumbuhan Ekonomi Negara-Negara ASEAN pada Periode 2005-2016. *Impact of Telecommunication Service Diffusion on Economic Growth of ASEAN Countries in the Period of 2005-2016*. 16(1), 1–16. <https://doi.org/10.17933/bpostel.2018.160101>
- Bakkrara, C. A. (2017). Dampak Keterbukaan Perdagangan Terhadap Perkembangan Ekonomi di ASEAN-10. Universitas Katolik Parahyangan.
- BPS. (2019). Statistik Telekomunikasi Indonesia 2019. https://www.bps.go.id/publication/2020/12/02/be999725b7aeee62d84c6660/s_tati_stik-telekomunikasi-indonesia-2019.html
- Chavula, H. K. (2013). Telecommunications development and economic growth in Africa. *Information Technology for Development*, 19(1), 5–23. <https://doi.org/10.1080/02681102.2012.694794>
- Donou-Adonsou, F., Lim, S., & Mathey, S. A. (2016). Technological Progress and Economic Growth in Sub-Saharan Africa: Evidence from Telecommunications Infrastructure. *International Advances in Economic Research*, 22(1), 65–75. <https://doi.org/10.1007/s11294-015-9559-3>
- Feng, Y. (2016). Internet and Economic Growth-Evidence from Chinese Provincial Panel Data. *Modern Ekonomi*, 7(859–866). <https://doi.org/10.4236/me.2016.78089>.
- Haftu, G. G. (2019). Information communications technology and economic growth in Sub-Saharan Africa: A panel data approach. *Telecommunications Policy*, 43(1), 88–99. <https://doi.org/10.1016/j.telpol.2018.03.010>
- Insani, R. N., & Indra, I. (2015). Analisis Faktor-Faktor yang Memengaruhi Tingkat Pertumbuhan Ekonomi pada 20 Negara OKI Tahun 2009-2013. *Muqtasid: Jurnal Ekonomi Dan Perbankan Syariah*, 6(2), 141.

- <https://doi.org/10.18326/muqtasid.v6i2.141-156>
- Ipa Jamiah Arfa, A. (2015). Pengaruh Perdagangan Dan Penanaman Modal Asing Terhadap Pertumbuhan Ekonomi Di Indonesia: Sebuah Aplikasi Autoregressive Distributed Lag Model (Ardl. Jurnal Ilmu Ekonomi, 3(3), 1–10.
- Katz, R. L., & Koutroumpis, P. (2014). The Economic Impact of Telecommunications in Senegal. 2012(86), 129–150. https://doi.org/10.1007/978-3-319-03617-5_11
- Koyuncu, C., & Unver, M. (2016). The Impact of Infrastructure on FDI Inflows : A Panel Data Analysis The Impact Of Infrastructure On FDI Inflows : A Panel Data Analysis. World Economy, 21.
- Maulidiyah, H. (2018). Analisis Pengaruh Tingkat Keterbukaan Perdagangan dan Foreign Direct Investment terhadap Pertumbuhan Ekonomi (Studi Kasus Lima Negara Pendiri ASEAN). Universitas Islam Negeri Sunan Kalijaga Yogyakarta.
- Menajang, H. (n.d.). PENGARUH INVESTASI DAN TENAGA KERJA TERHADAP PERTUMBUHAN EKONOMI KOTA MANADO. Fakultas Ekonomi Universitas Sam Ratulangi.
- Munthe, M. N. (2014). PERTUMBUHAN EKONOMI DI INDONESIA. 18.
- Murtiadi, M. R. (2019). Dampak Teknologi Informasi dan Komunikasi Terhadap Pertumbuhan Ekonomi dan Pembangunan Manusia di Indonesia. Universitas Padjadjaran.
- Myovella, G., Karacuka, M., & Haucap, J. (2020). Digitalization and economic growth: A comparative analysis of Sub-Saharan Africa and OECD economies. Telecommunications Policy, 44(2), 101856. <https://doi.org/10.1016/j.telpol.2019.101856>
- PRASETYO, G. A. (2016). PENGARUH PEMBANGUNAN INFRASTRUKTUR TELEKOMUNIKASI TERHADAP PERTUMBUHAN EKONOMI DI ASEAN. Universitas Airlangga.
- Rath, B. N., & Hermawan, D. (2019). Do information and communication technologies foster economic growth in Indonesia? Buletin Ekonomi Moneter Dan Perbankan, 22(1), 103–121. <https://doi.org/10.21098/bemp.v22i1.1041>
- Samoilenko, S., & Osei-Bryson, K. M. (2008). An exploration of the effects of the interaction between ICT and labor force on economic growth in transition economies. International Journal of Production Economics, 115(2), 471–481. <https://doi.org/10.1016/j.ijpe.2008.07.002>
- Sridhar, K. S., & Sridhar, V. (2008). Telecommunications Infrastructure and Economic Growth: Evidence from Developing Countries. Telecommunications Infrastructure and Economic Growth: Evidence from Developing Countries, 7(2), 37–56.
- Suradi. (2012). Pertumbuhan Ekonomi dan Kesejahteraan Sosial (Economic Growth and Social Welfare). Informasi, 17(03).
- Virtyani, M. Z., Hendrati, I. M., & Asmara, kiki. (2021). ANALISIS PEMBENTUKAN MODAL TETAP BRUTO , INVESTASI ASING LANGSUNG , DAN EKSPOR TERHADAP PENDAPATAN NASIONAL PERKAPITA INDONESIA (DALAM MENGHINDARI MIDDLE INCOME TRAP) Upper-middle income Low income High income menghadapi tantangan

untuk menghindari Midd. Inovasi Manajemen Dan Kebijakan Publik, 4(1), 47–60.

Yogaswara, A. R. (2015). PERANAN TEKNOLOGI INFORMASI DAN KOMUNIKASI (TIK) DALAM PERTUMBUHAN EKONOMI DI NEGARA-NEGARA BERKEMBANG. <http://pusdiklat.kemenperin.go.id/>